



## *OPERATING AND MAINTENANCE MANUAL*

Product: ***Live Line Tester***

Type: ***3.3kV, 6.6kV, 11kV, 13.8kV & 33kV***

*MANUFACTURED BY:*

**High Voltage Instruments Ltd.**

15-16 Woodbridge Meadows, Guildford, Surrey, GU1 1BJ, United Kingdom

Telephone: 01483 207428

email: [sales@hvil.com](mailto:sales@hvil.com)



# CONTENTS



<b>1</b>	<b>SAFETY RULES</b>	<b>5</b>
<b>2</b>	<b>DESCRIPTION</b>	<b>7</b>
2.1	GENERAL	7
2.2	PRINCIPLE OF OPERATION	7
2.3	PROVING	7
2.4	LIMIT MARK	8
<b>3</b>	<b>INSTRUCTION FOR USE</b>	<b>9</b>
3.1	LIST OF EQUIPMENT	9
3.2	ASSEMBLING THE EQUIPMENT	10
3.3	USING THE EQUIPMENT	12
<b>4</b>	<b>SPECIFICATIONS</b>	<b>18</b>
4.1	ELECTRICAL	18
4.2	MECHANICAL	20
4.3	ENVIROMENTAL	23
<b>5</b>	<b>CARE AND MAINTENANCE</b>	<b>24</b>
5.1	STORAGE	24
5.2	TRANSPORTING	24
5.3	CLEANLINESS	24
5.4	MECHANICAL DAMAGE	24
5.5	RECALIBRATION AND PROOF TESTING	24

<b>6</b>	<b>SPARES AND ACCESSORIES</b>	<b>25</b>
<b>7</b>	<b>LIMITED WARRANTY</b>	<b>26</b>
<b>8.</b>	<b>REVISION</b>	<b>28</b>

# 1 SAFETY RULES



- 1.1 Only personnel who are fully trained in the use of Live Line Testers should use this equipment. The systems that it will be used on are powered from high voltages which can be lethal
- 1.2 Before use ensure that the Tester and the accessories that are required for use are clean, free from cracks or deep scores, and are properly secured together.
- 1.3 Make certain that the Tester is properly rated for the voltage of the system under test.
- 1.4 Test the operation of the assembled Tester complete with accessories before and after each test (refer to Section 3).
- 1.5 Do not allow a live high voltage conductor to come in contact with the detector at point below the limit mark.
- 1.6 The Tester must never be used without a handle or without insulating rods incorporating a handle.
- 1.7 Safe working distances must always be observed.

- 1.8 Always connect the earth lead clip to a secure earthing point before performing a test. If the earth clip becomes disconnected during a test never handle the earth lip until the tester is removed from the line under test.

REMEMBER

SAFETY IS NO ACCIDENT!

THIS TESTER SHOULD ONLY BE USED BY A COMPETENT,  
SUITABLY TRAINED PERSON.

## **2 DESCRIPTION**

### **2.1 GENERAL**

The HVIL range of Live Line Testers has been designed for use on overhead lines and on switchgear. Models are available to cover system voltages from 3.3kV to 33kV 50/60Hz and can be used indoors and outdoors in all weathers.

Testers are used to measure the voltage between a line or conductor and earth or to check the phase relationship between two voltages.

### **2.2 PRINCIPLE OF OPERATION**

A Live Line Tester is a device that draws current from the source under test. This current flows through a resistive chain to earth via an earth lead. The current flow is monitored and displayed on a moving coil meter which is graduated in kV.

When checking phase relationships a Phasing Rod is used in conjunction with a Live Line Tester. Currents from two sources are combined and displayed on the meter on the Tester. In-phase voltages will read twice the phase to earth voltage and out-of-phase voltages will read the phase to earth voltage only.

### **2.3 PROVING**

Before and after using a Live Line Tester and associated accessories a functional test should be performed on the assembled items. A proving unit is provided for this purpose.









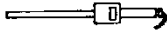
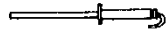

## **2.4**      ***LIMIT MARK***

Near the contact end of the Tester and Phasing Rods there is a red band which is the limit mark. By definition this mark indicates the physical limit to which these items may be inserted between live components or may touch them.



# 3 INSTRUCTION FOR USE

## 3.1 LIST OF EQUIPMENT

LIST OF EQUIPMENT					
PRODUCT	PART NO.				
	up to 3.3kV	up to 6.6kV	up to 11kV	up to 13.8kV	up to 33kV
 Tester c/w earth cord	F0262B	F0264B	F0256B	F0260B	F0257B
 Phasing rod c/w phasing lead	F0263B	F0265B	F0258B	F0261B	F0259B
 Bent end adaptor	DFH502B	DFH502B	DFH502B	DFH502B	DFH502B
 Extension rod	DFH5002	DFH5002	DFH5002	DFH5002	DFH5026
 Bowthorpe rod adaptor c/w lead	DFK0112	DFK0112	DFK0112	DFK0112	DFK0112
 Overhead line adaptor	DFK5000	DFK5000	DFK5000	DFK5000	DFK5000
 Proving unit c/w leads	FOP01B	FOP01B	FOP01B	FOP01B	FOP01B
 Repeater unit	FOR05B	FOR04B	FOR01B	FOR03B	FOR02B
 Carry case 1	CMP5009	CMP5009	CMP5009	CMP5009	
 Carry case 2	CMP5008	CMP5008	CMP5008	CMP5008	CMP5008
 Carry bag	CMP5010	CMP5010	CMP5010	CMP5010	CMP5023

## 3.2 ASSEMBLING THE EQUIPMENT

### 3.2.1 For Use on Overhead Lines from Poles or Towers

#### 3.2 ASSEMBLING THE EQUIPMENT

##### 3.2.1 For Use on Overhead Lines from Poles or Towers

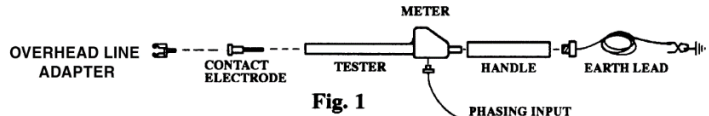

Fig. 1

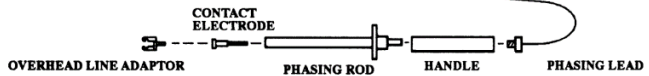

Fig. 2

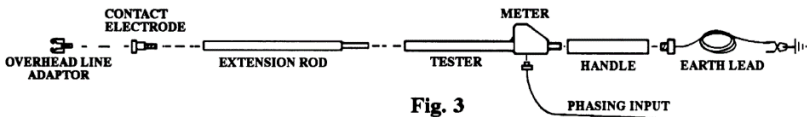
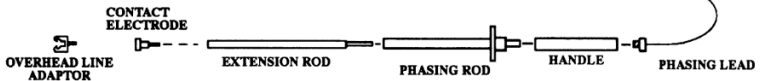

Fig. 3



When voltage tests are to be carried out on overhead lines from poles or towers, the Tester should be assembled as shown in Fig. 1. If a longer reach is required then an Extension Rod can be added as in Fig. 3.

If it is required to check the phase relationship between the voltages on two conductors then the Phasing Rod should be assembled as shown in Figs. 2 and 4 and linked to the Tester phasing inputs in Figs. 1 and 3 respectively.

### 3.2.2 For Use on Overhead Lines from Ground Level

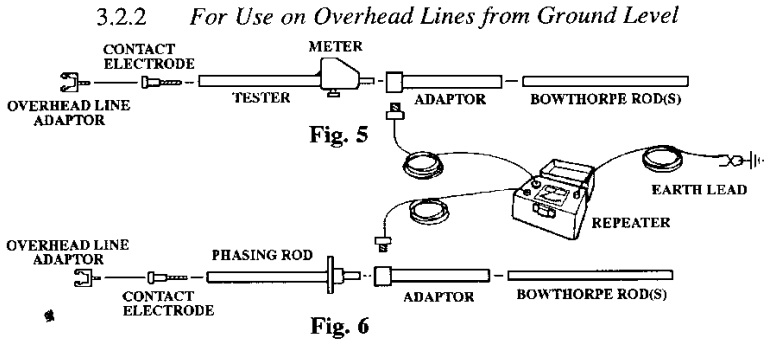

When performing voltage tests from ground level the Tester is assembled as shown in Fig. 5 with sufficient Bowthorpe rods to give the necessary reach. The Repeater is placed on the ground and the readings displayed are the same as those on the Tester.

To carry out phasing tests the Phasing Rod is assembled as shown in Fig. 6 and then coupled to the Repeater in Fig. 5 so that the resultant voltage is displayed.

The Tester in Fig. 5 can be replaced with a Phasing Rod since the meter on the Tester is often not visible and the readings are taken from the meter on the Repeater Unit.

### 3.2.3 For Use on Switchgear

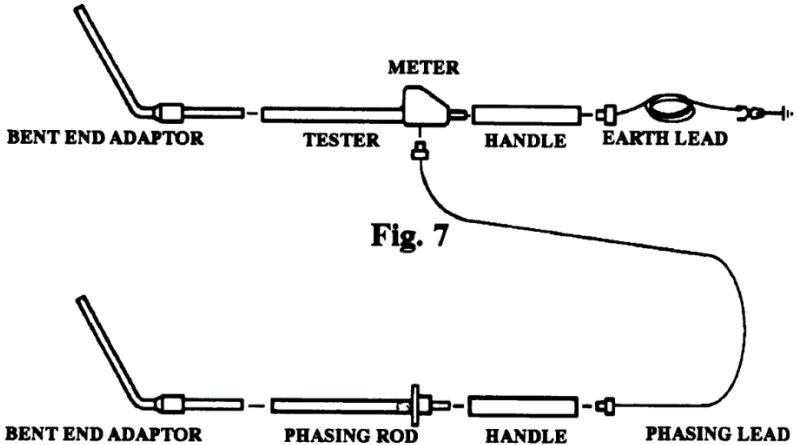

**Fig. 8**

To measure voltages on switchgear the Tester is assembled as shown in Fig. 7. The meter on the Tester can be rotated to the line up with the Bent End Adaptor for ease of reading.

When performing phasing tests, the Phasing Rod is assembled as shown in Fig. 8 and linked to the Tester phasing input on the meter in Fig. 7.

## **3.3 USING THE EQUIPMENT**

- 3.3.1 Assemble the equipment as required; refer to section 3.2.
- 3.3.2 The completely assembled equipment must be proved before and after use. A Proving Unit is provided which generates a nominal

### 3.3.3 Proving a Tester

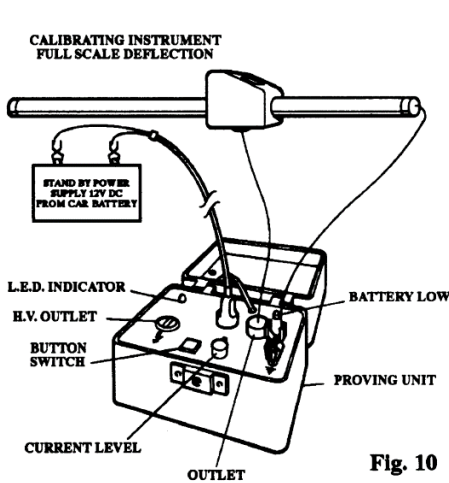

Fig. 10

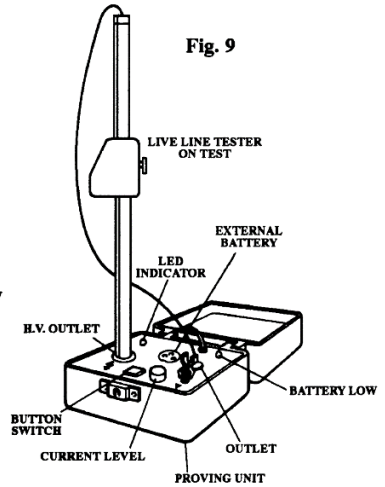

Fig. 9

To check the high resistance chain, connect the Tester to the Proving Unit and insert the contact electrode into the high voltage outlet as in Fig. 9. Observe good battery condition (low battery in the proving unit is indicated by a flashing light). Check that the meter on the Tester reads between 3 and 5kV.

NOTE: In the event of low battery indication, remove battery cover lid of proving unit and replace batteries. If replacement batteries are not readily available, the proving unit can be powered from a standard 12V vehicle battery using the lead provided as shown in Fig. 10.

To check for full scale deflection of the meter, connect the Tester to the Proving Unit as shown in Fig. 10.

### 3.3.4 Proving a Phasing Rod

A Phasing Rod may be proved using a Proving Unit in conjunction with a Tester or a Repeater Unit, refer to Figs. 11 and 12.

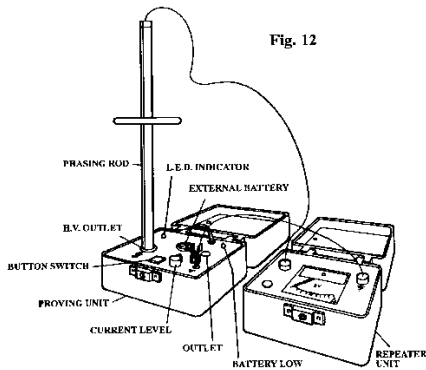
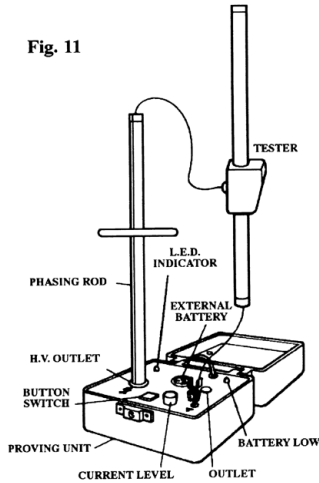

In each case the Phasing Rod contact electrode is inserted into the high voltage outlet on the proving unit and the meter on the Tester or Repeater Unit should read between 3 and 5kV.

3.3.5 Proving an Extension Rod/Bent End Adaptor Fit an Extension Rod or Bent End Adaptor to a Tester and perform the test detailed in 3.3.3.

### 3.3.6 *Measuring Voltages*

With the equipment assembled as in figures 1,3 or 5 as necessary firstly connect the earth lead clip to a secure earthing point. Now touch the Tester onto the line under test and the voltage will be displayed on the meter.

Note: The voltage will also be displayed on the repeater if incorporated.

### 3.3.7 *Checking phase Relationships*

To check phase relationships the equipment should be assembled as in figures 1/2, 3/4, 5/6 and 7/8 as necessary. Each phase to earth voltage should firstly be measured and then the combined / resultant voltages are measured and compared with the values for the individual phases.

If the voltages on the two phases are in-phase then the resultant voltage to earth is twice the phase voltage. If the voltages are out-of-phase then the resultant voltage to earth is the same as the phase voltage.

PHASE	SYSTEM VOLTAGE					
	3.3	6.6	11	13.8	33	
<b>A1</b>	1.9	3.8	6.35	8	19	<b>PHASE VOLTAGE TO EARTH kV</b>
<b>B1</b>	1.9	3.8	6.35	8	19	
<b>C1</b>	1.9	3.8	6.35	8	19	
<b>A2</b>	1.9	3.8	6.35	8	19	
<b>B2</b>	1.9	3.8	6.35	8	19	
<b>C2</b>	1.9	3.8	6.35	8	19	
<b>A1+A2</b>	3.8 in-phase	7.6 in-phase	12.7 in-phase	16 in-phase	38 in-phase	<b>RESULTANT VOLTAGE TO EARTH kV</b>
<b>A1+B2</b>	1.9) out	3.8) out	6.35) out	8) out	19) out	
<b>A1+C2</b>	1.9) of	3.8) of	6.35) of	8) of	19) of	
<b>A1+A2</b>	1.9) phase	3.8) phase	6.35) phase	8) phase	19) phase	
<b>B1+B2</b>	3.8 in-phase	7.6 in-phase	12.7 in-phase	16 in-phase	38 in-phase	
<b>B1+C2</b>	1.9) out	3.8) out	6.35) out	8) out	19) out	
<b>C1+A2</b>	1.9) of	3.8) of	6.35) of	8) of	19) of	
<b>C1+B2</b>	1.9) phase	3.8) phase	6.35) phase	8) phase	19) phase	
<b>C1+C2</b>	3.8 in-phase	7.6 in-phase	12.7 in-phase	16 in-phase	38 in-phase	

Table 1

If it is required to check phase relationships on overhead lines, then the set-up as shown in Fig. 14 can be used with Bowthorpe Rod Adaptors and Rods fitted to Phasing Rods carrying Overhead Line Hooks.

NOTE: Either or both Phasing Rods can be replaced by a Tester.



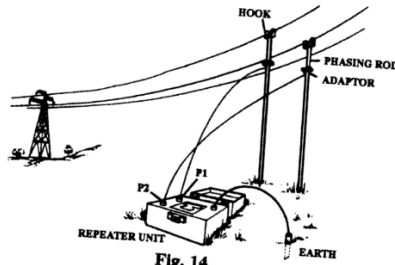

Fig. 14

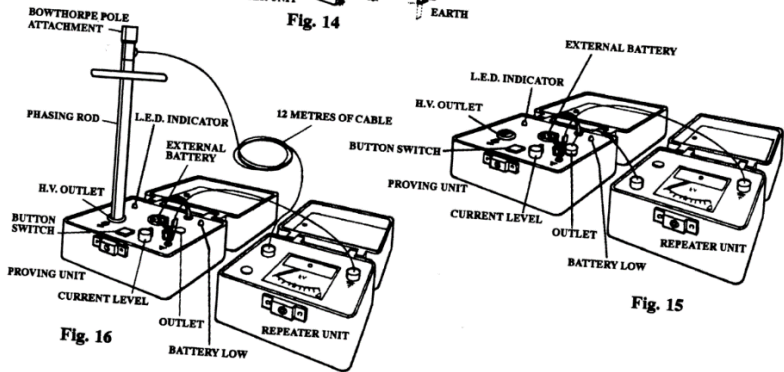

Fig. 16

Fig. 15

Using the set-up shown in Fig. 15 check the full scale deflection of the meter on the Repeater Unit by depressing the Proving Unit operating button and rotating the current level control.

Fig. 16 shows the set-up for proving a Phasing Rod with a Bowthorpe Adaptor, in place of a handle, in conjunction with a Repeater Unit. Each Phasing Rod is proved in turn by inserting its contact end into the HV outlet and observing that the meter on the Repeater Unit indicates between 3 and 5kV.

Using one Phasing Rod assembly, check each line voltage and note the readings. Then, using both Phasing Rods, the resultant voltages to earth are measured and compared with the line voltages to ascertain the phase relationship.

## 4 SPECIFICATIONS

### 4.1 ELECTRICAL

<i>TESTER</i>					
SYSTEM VOLTAGE	3.3kV	6.6kV	11kV	13.8kV	33kV
Resistor Chain Value ( $\pm 5\%$ )	22.5M $\Omega$	52.5M $\Omega$	75M $\Omega$	100M $\Omega$	225M $\Omega$
Measuring Range	5kV	10kV	15kV	20kV	40kV
Accuracy	$\pm 5\%$ of FSD				
Movement	100 $\mu$ A taut band suspension				

<i>PHASING ROD</i>	
Resistor Chain Value	As for Tester

<i>REPEATER UNIT</i>	
Measuring Range	As for Tester
Accuracy	As for Tester
Movement	As for Tester

<i>PROVING UNIT</i>	
Battery	8 X 1.5V IEC R20 or equivalent
Battery Consumption	<200mA on high voltage generation with 12V supply
High Voltage Output	3 to 5kV D.C. at 100 $\mu$ A max. current
Low Voltage A.C. source	Variable 0 to 200 $\mu$ A at 50Hz nominal with a short circuit current of <1mA

<i>SAFETY</i>	
EMC	To BS EN 50081-1 To BS EN 50082-1

**4.2****MECHANICAL**

<i>TESTER</i>		
SYSTEM VOLTAGE	3.3kV to 13.8kV	33kV
Length	1025mm	1200mm
Weight	2000gm	2300gm
Material	PVC. Moulded polycarbonate. Resin bonded fibreglass, Aluminium / Stainless Steel	
Meter Housing Adjustment	340° stop to stop	

<i>PHASING ROD</i>		
SYSTEM VOLTAGE	3.3kV to 13.8kV	33kV
Length	1025mm	1200mm
Weight	1400gm	1600gm
Material	PVC. Moulded polycarbonate. Resin bonded fibreglass, Aluminium / Stainless Steel	

<i>EXTENSION ROD</i>		
SYSTEM VOLTAGE	3.3kV to 13.8kV	33kV
Length	907mm	907mm
Weight	650gm	700gm
Material	PVC. Resin bonded fibreglass, Aluminium / Stainless Steel	

<i>BOWTHORPE ROD ADAPTOR</i>		
Length	360mm	
Weight	1350gm	
Material	Resin bonded fibreglass, Aluminium / Stainless Steel	

<i>BENT END ADAPTOR (STANDARD)</i>		
Length (developed)	675mm	
Weight	270gm	
Material	Moulded polypropylene Stainless Steel	

<i>OVERHEAD LINE ADAPTOR</i>	
Length	90mm
Weight	100gm
Material	Aluminium / Stainless Steel

<i>REPEATER AND PROVING UNITS</i>	
Case Dimensions	185 x 145 x 152mm
Case Material	Moulded ABS
Vibration Resistance	To IEC 68-2-6
Drop Resistance	To IEC 68-2-32
Shock Resistance	To IEC 529

### 4.3 **ENVIROMENTAL**

Operating Temperature	-25°C to +50°C
Water Ingress	To IEC 529  'wet' testing according to IEC Technical Committee No 78, i.e. all items except he proving unit may be used outdoors in all weathers
Cold Temperature	To IEC 68-2-1
Dry Heat	To IEC 68-2-2
Damp Heat	To IEC 68-2-3

## **5 CARE AND MAINTENANCE**

### **5.1 STORAGE**

The Tester and its accessories should be stored in the proprietary carrying case/bag when not in use.

### **5.2 TRANSPORTING**

When the equipment is in transit it should be stored in its carrying case/bag. Whilst the equipment has been designed for field use it should not be subjected to excessive bumps and shocks.

### **5.3 CLEANLINESS**

Dirt can cause surface tracking and it is therefore necessary to keep the Tester and its accessories clean by washing with detergent solution. The Tester and other parts constructed from fibreglass and PVC should then be polished with the liquid polymer polish provided.

### **5.4 MECHANICAL DAMAGE**

If surface scratches or dents can easily be seen by the naked eye, then the equipment should be returned to the manufacturer for repair since these blemishes act as traps for dirt and moisture. Mechanical damage to screw threads would also necessitate the return of the equipment to the manufacturer.

### **5.5 RECALIBRATION AND PROOF TESTING**

Every twelve months the Tester and its accessories should be rechecked. This should include pressure testing, radial voltage proof testing, torque testing of bushes and accuracy of indication. It is recommended that this be carried out by the manufacturer.



## **6 SPARES AND ACCESSORIES**

6.1	Earth Lead	DFH5044
6.2	Proving/Phasing Lead	DFH5045
6.3	Hot Connector (Tester or Phasing Rod)	DDH5001
6.4	Hot Connector (Extension Rod)	DDH5000
6.5	Bent End Adaptor	DFH5028
6.6	Cleaning Kit	DDM5003
6.7	Battery 8 X 1.5V Type IEC R20	CEJ0000
6.8	Instruction Manual	CMR0059

## **7 LIMITED WARRANTY**

High Voltage Instruments Ltd warrant instruments and test equipment manufactured by them to be free from defective material or factory workmanship and agree to repair or replace such products which, under normal use and service, disclose the defect to be the fault of our manufacturing, with no charge for parts and service. If we are unable to repair or replace the product, we will make a refund of the purchase price. Consult the Instruction Manual for instructions regarding the proper use and servicing of instruments and test equipment. Our obligation under this warranty is limited to repairing, replacing or making refund of any instrument or test equipment which proves to be defective within twelve months from the date of original purchase.

This warranty does not apply to any of our products which have been repaired or altered by unauthorised persons in any way so as, in our sole judgement, to injure their stability or reliability, or which have been subject to misuse, abuse, misapplication, negligence or accident or which have had the serial numbers altered, defaced or removed. Accessories, not of our manufacture used with this product, are not covered by this warranty. To register a claim under the provisions of this warranty, return the instrument or test equipment to

**High Voltage Instruments Ltd,  
15-16 Woodbridge Meadows  
Guildford, GU1 1BJ, U.K.**

Upon our receipt and inspection of the product we will advise you as to the disposition of your claim.

ALL WARRANTIES IMPLIED BY LAW ARE HEREBY LIMITED TO A PERIOD OF TWELVE MONTHS, AND THE PROVISIONS OF THE WARRANTY ARE EXPRESSLY IN LIEU OF ANY OTHER WARRANTIES EXPRESSED OR IMPLIED.

The purchaser agrees to assume all liability for any damages and bodily injury which may result from the use or misuse of the product by the purchaser, his employees, or others, and the remedies provided for in this warranty are expressly in lieu of any other liability High Voltage Instruments Ltd may have including incidental or consequential damages.

High Voltage Instruments Ltd reserve the right to discontinue models at any time, or change specification, price or design, without notice and without incurring any obligation.

## 8. REVISION

Product / Type:

File: HVOM0007

Author: D. Maxim

Issue / Date: 1/15.09.22

Modified By: MC CCN1619

Checked By: K. Smith	Date: 22.09.2022
----------------------	------------------